

WATER VALVE SHUTOFF

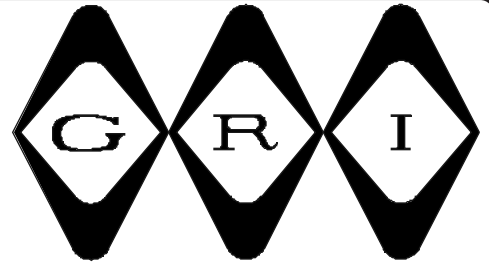

WVS

- ◆ Monitors Flooding From Leaking or Broken Water Line
- ◆ Automatic Control of Main Water Supply Line
- ◆ Form C Relay Output For External Monitoring Devices
- ◆ Visual and Audible Status Indicators
- ◆ Automatic Self Testing
- ◆ Covers Large Area When Used With Multiple Sensors
- ◆ Low Voltage Design With Battery Backup



WVS

The G.R.I. Water Valve Shutoff System was designed as a flood prevention device. This system utilizes an electronic controller to provide automatic control of an electronic water valve that is installed in the main water supply line. The controller continually monitors water sensors that are placed in areas where flooding from water line breaks are most likely to occur; washing machine, hot water heater, sinks, dishwasher.

When water is sensed by the water sensor, the sensor will signal the controller of the presence of water. The controller then automatically powers the electronic valve and signals it to close. Once the controller senses that the valve is in the closed position, the controller will then trigger the C form relay that can be used to signal a remote monitoring device, such as an alarm panel or auto dialer. While in this alarm condition, the controller will annunciate an audible alarm and flash an alarm indication LED. The controller will stay in this alarm condition with the valve closed up until the reset button is depressed. When the reset is depressed while in the alarm mode, the controller will either open the valve and return to the normal monitoring mode or if the sensor still senses the presence of water, the controller will annunciate an alarm condition and the valve remains in the closed position.

At any time, the position of the valve can be changed with the use of the controller simply by depressing and holding down the reset button. If the valve is open, a press and hold will cause the valve to close. If the valve is closed, a press and hold will open the valve.

WARRANTY:

One year warranty against workmanship, material and factory defects.

GEORGE RISK INDUSTRIES, INC.
G.R.I. PLAZA
KIMBALL, NE 69145



MADE IN U.S.A.

TOLL-FREE 1-800-445-5218 • 1-800-523-1227

(308) 235-4645

FAX (308) 235-3561

E-MAIL: grisales@megavision.com

WEB SITE: www.grisk.com



WATER VALVE SHUTOFF

WVS:

The G.R.I. Water Valve Shutoff System was also designed to monitor itself. The controller periodically checks for a signal sent to the controller from both the water sensor and the electronic valve. If either signal is missing or incorrect, the controller will enter a trouble mode. When a trouble occurs a trouble annunciation is sounded and a flashing LED will be displayed. Four green LED flashes indicate a trouble with the water sensors and four red LED flashes indicate a trouble with the valve. Common troubles include loose or broken connecting wires or improper installation.

Another self test feature is a monthly cycling of the electronic valve. Once a month the controller will automatically close and reopen the valve to prevent corrosion buildup inside the valve and to physically check for proper operation of the electronic valve. A trouble condition will be displayed if the test fails.

SPECIFICATIONS:

Operating Voltage	9 to 12 VDC
Max. Voltage	13.5 VDC
Average Current	55mA with 5 Sensors
Max. Current	300mA
Backup Battery	9V Alkaline

Valve

Pipe Size	1" NPT
Height	4 1/2"
Width	3 1/4"
Length	3 1/4"

Relay Contacts:

Contact Resistance	100 mOhms
Max. Switching Power	DC 30W - AC 60 VA
Max. Switching Volts	60 VDC - 120 VAC
Max. Switching Current	2A DC/AC

Max. Water Sensors	5
Max. Wire Length to Sensors	200 ft.
Max. Wire Length to Valve	50 ft.

Optional Not Included: 2600/2600T (max. 4)

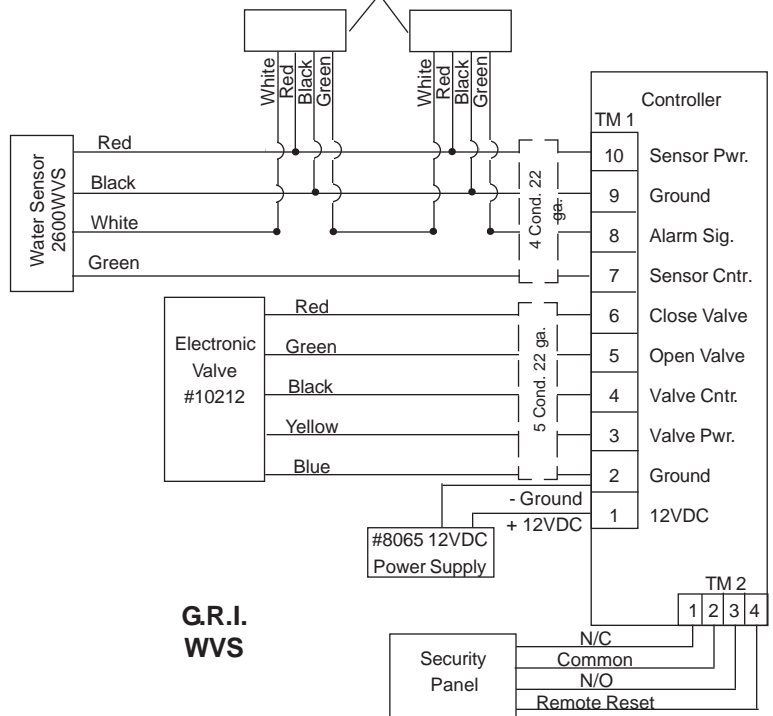

**G.R.I.
WVS**

Items Included:

- 1 - Electronic Controller
- 1 - Electronic Water Valve
- 1 - Water Sensor 2600WVS
- 1 - 12 VDC Regulated Power Supply 8065
- 9 - Connectors

Optional Items:

- 2600 Water Switches 2600/2600T

CONTACT YOUR G.R.I. DISTRIBUTOR OR CALL:

GEORGE RISK INDUSTRIES, INC.
G.R.I. PLAZA
KIMBALL, NE 69145



MADE IN U.S.A.

TOLL-FREE 1-800-445-5218
TOLL-FREE 1-800-523-1227
(308) 235-4645
FAX (308) 235-3561

E-MAIL: grisales@megavision.com
WEB SITE: www.grisk.com